

AZZURRO - SINGLE-PHASE STRING INVERTERS

3000TLM/3680TLM/4000TLM
4600TLM/5000TLM/6000TLM



The TLM series **single-phase ZCS Azzurro** inverters are the ideal solution for residential or commercial type PV systems. They are available in versions from 3 to 6 Kw and are small, easy to manage, simple to install and all equipped with double MPPT channel.

Their wide input range makes them easy to configure and are suitable for all requirements on both new and retrofit installations on existing systems.

The multi-function graphic display provides instant viewing of all data and the WiFi connection provides zero cost remote monitoring.



AZZURRO ZCS TECHNOLOGY

- Performance optimisation
- WiFi integration on the ZCS platform for stable, effective and intelligent connectivity



MAXIMUM ENERGY EFFICIENCY

- Maximum performance 97.6%
- Stable efficiency in all working conditions
- Rapid and accurate MPPT algorithm
- Dual input section with independent MPPT



A FLEXIBLE, ECONOMIC AND EASY INSTALLATION SOLUTION

- IP65 Protection rating
- "Plug & Play" AC and DC side connections
- Wireless communication with integrated Web Server
- 4" LCD display
- Standard or fast Enel Autotest versions
- Updates and diagnostics through SD Card



RELIABILITY, STURDINESS AND FLEXIBILITY

- External enclosure in rust-proof, corrosion-proof and UV-ray proof aluminium
- Natural ventilation cooling
- Fast and flexible management of operating parameters
- Simple and user-friendly monitoring
- 10 year ZCS warranty



INTELLIGENT GRID MANAGEMENT

- Dynamic management of delivery to the grid
- "Zero Delivery" grid function*
- Remote control over deliverable active/reactive output limit



IDEAL FOR RETROFIT OPTIONS

- Wide operating input range from 100V to 550V
- Compact size
- Simple and user-friendly installation and configuration
- Dual MPPT channel



*Possible through current sensor (ZST-ACC-TA)

FLOW CHART

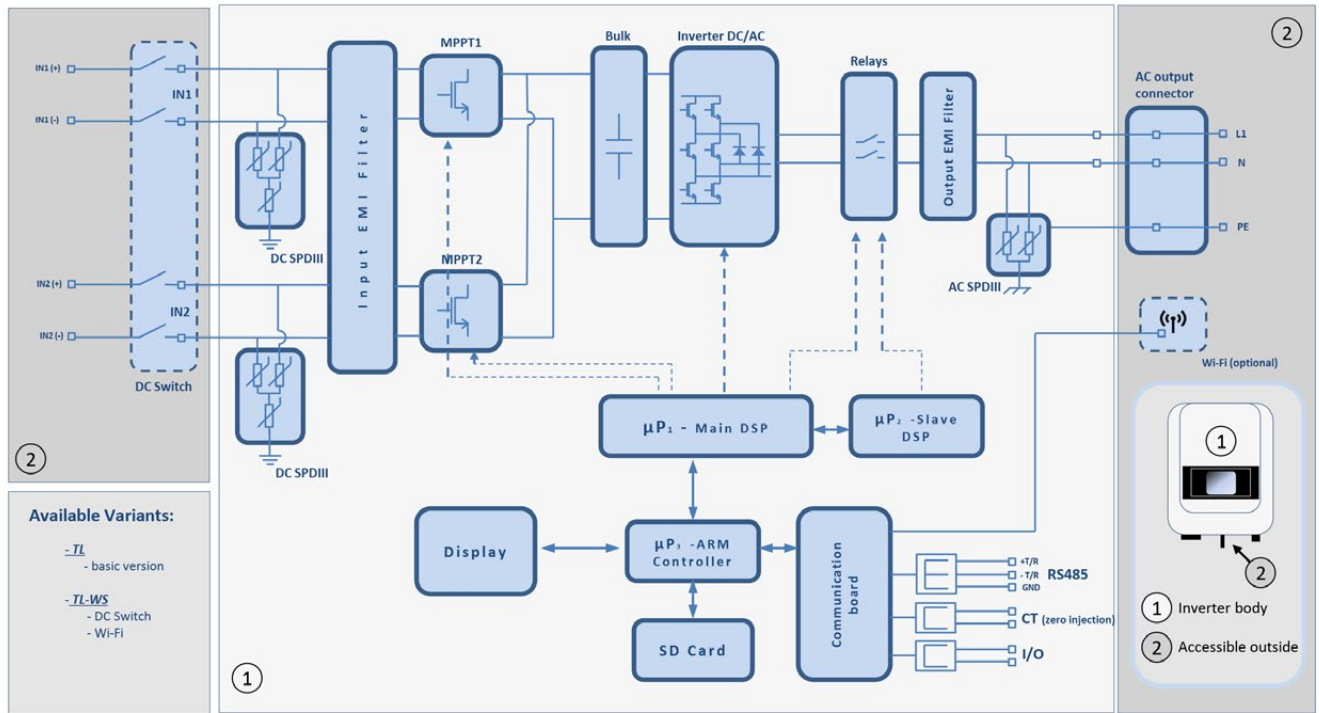

EFFICIENCY CURVE

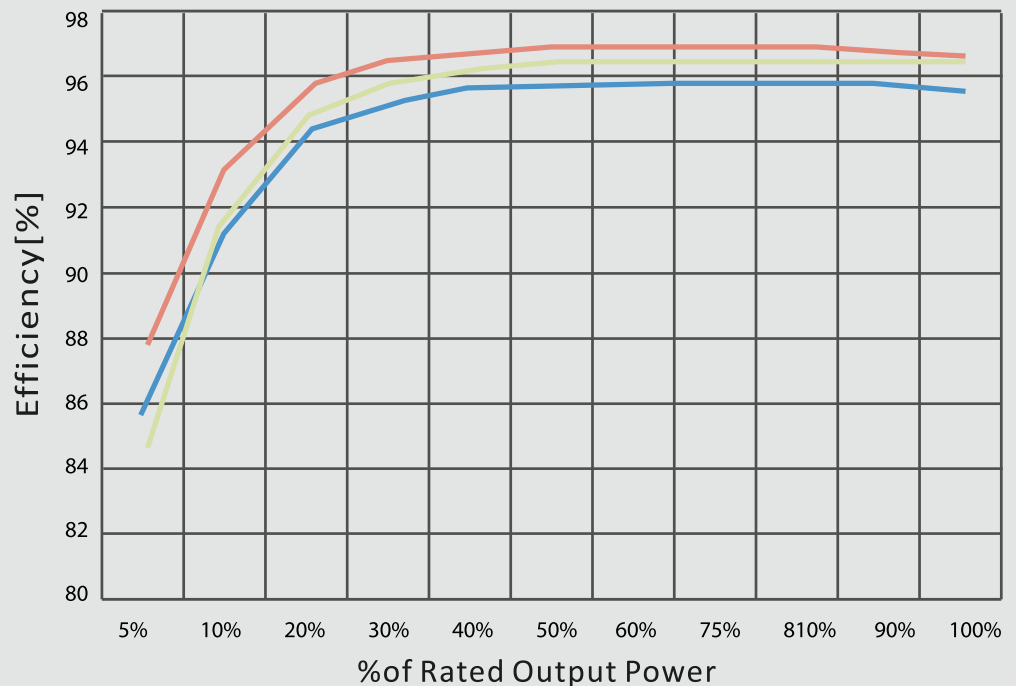

DATI TECNICI	3000TLM	3680TLM	4000TLM	4600TLM	5000TLM	6000TLM
Input (DC)						
Rated input DC power	3300W	4000W	4400W	5000W	5500W	6600W
Maximum DC power for each MPPT	2000(200V-500V)	2400(200V-500V)	2600(200V-500V)	3000(200V-500V)		3150(250V-520V)
Number of independent MPPTs	2					
Number of DC Inputs	1 for each MPPT					
Maximum Input Voltage	600V					
Activation voltage	100V	120V				
Rated Input Voltage	360V					
MPPT DC Voltage range	80V-580V	100V-580V				
DC voltage range at full load	160V-520V	165V-520V			175V-520V	250V-520V
Max Input current per MPPT	10A/10A	12A/12A	13A/13A	15A/15A		
Short Circuit Current for each MPPT	12A	14A	16A	18A		
Output (AC)						
Nominal AC power (@ 230V, 50Hz)	3000VA	3680VA	4000VA	4600VA	5000VA	6000VA
Maximum AC Power	3000VA	3680VA	4000VA	4600VA	5000VA	6000VA
AC Rated Voltage	L/N/PE, 220,230,240V					
Rated AC Voltage Range	180V-270V (According to the local network standard)					
Mains frequency	47~53 / 57~63 Hz (According to the local network standard)					
Active Power Adjustment Range	0~100%					
Maximum AC Current	13A	16A	17.5A	20A	22A	26A
Total current harmonic distortion	<3%					
Power factor	1 (adjustable +/- 0.8)					
Input limitation on the network	Input adjustable from zero to the rated value					
Efficiency						
Maximum Efficiency	97.6%					
Weighted efficiency (EURO)	97.1%/97.3%					
Night Consumption	<1W					
Start Power Threshold	20W					
MPPT efficiency	>99.5%					
Protection						
Reverse Polarity Protection	Yes					
DC Switch	Opzionale					
Protection class/Surge Category	I/III					
Input/Output MOV (III)	Yes					
Safety Protection	Anti islanding, RCMU, Ground fault monitoring					
Safety Certificates	CE, IEC 62109-1, IEC 62109-2, IEC 62116, IEC 61727, IEC 60068(1,2,14,30), IEC61683					
Mains Certificates	AS 4777, AS3100, VDE-AR-N 4105, G83/G59, CEI 0-21, C10/11					
Communication						
Power Management Unit	According to network requirements and certifications					
Standard Communication Mode	wifi (optional) + RS485 + SD card (optional)					
Data storage	25 years					
General Information						
Ambient temperatures	-25°C...+60°C					
Insulation level	Transformerless					
Protection rating	IP65					
Relative humidity	0...95% Without Condensation					
Maximum operating altitude	2000m					
Noise level	<25db@1m					
Weight	18kg			19kg		
Cooling system	Natural					
Dimensions (H x W x D)	344*478*170mm					
Warranty	10 years					



AS4777 G83/2 G59/3

CE, CEI 0-21, CQC, IEC, VDE-AR-N4105/VDE-0126, EMC, C10/11, EN50438, RD1669